

DRILLING RIG INVENTORY

Rig Number: 730
Make & Model: Loadcraft HRI-850
Year Manufactured: 2006 Type: Mobile Drilling Rig Telescoping Double
Maximum Depth Rating with 4-1/2" 16.6 ppf Drill pipe: 12,000'
Rotary Drive: Type and Size, Speed Range (rpm): Hacker 22" 0-150 RPM
Approximate number of loads to move rig: 20

Drawworks:
Main Drum: Coffeyville Parmac Inc
Hydromatic Brake: 224DR Cable Size: 1 1/8 Number of Clutches: 2
Make & Model: Heartland Rig
Sand Drum: N/A Cable Size: N/A Cable Length: N/A
Engines: Make & Model: 2- Cat C -15 576hp Each

Derrick:
Manufacturer: Loadcraft Height: 116" Weight Capacity: 410,000
Maximum Number of Lines: 10 Last Inspection Date: 2009

Top Drive:
Manufacturer: Tesco Description: HMI-250
Capacity: 250 Ton 475hp Power Package

Iron Roughneck: National Oil Well Varco
Manufacturer: Varco Model: ST-80C

Substructure:
Height and Capacity: 14' 6" Rotary Beam Cap. 408,000 Set Back Cap225,000
Height above base of substructure to underside of rotary beams: 11'6"
Windbreak on substructure: X Yes No

Traveling Blocks:
Make & Model: Mud King Products BHU 200 weight Capacity: 200 Ton Number of Lines: 10

Elevators: Make & Model: AOT E34904 250 ton

Catwalk: Length & Height: 59 ft 3 ft-11 inch

Pipe Racks: Length & Height: 20 ft 3 ft 8 1/2 inch

Drill Pipe: Size, Amounts, Connections, Grade: 3 1/2 & 4 1/2
Last inspection date & footage since last inspected: current

Drill Collars: (Minimum quantity required for running manufactures maximum weight on bit for each hole size)
Size (O.D. x I.D.): 6 3/8 OD 2 3/8 ID 4 15/16 ID 2 Number: 20 EACH SIZE
Last inspection date & footage since last inspected: _____

Pumps: Make, Model, Input HP: HRS F-1000 Qty. 2 (TWO) 1,000hp
Engine Make & Model: CATERPILLAR Cat 2006 3508 model HP 900
Liner Size and Stroke Length: 6"x10" Stroke
Max. Continuous Operating Pressure: 3,000lb
Pump Speed (spm): 140

Steel Mud Pit:
Dimensions: 6' TALL X 10' WIDE X 54' LONG Capacity: 476 BBLs Number of Compartments: 6
Shale Shaker Make & Model: (Double) Derrick Flo Line Cleaner 503 FLC
Charge Pump Make & Model: 4X5 Mission

BOP's: Make & Model: Shaffer LWS Double Hydraulic Size: 11"
Pressure Rating: 3000 PSI Date of Last Inspection: current

Rotating Head: Make & Model: Washington Rotating Head
Estimated cost for stripping rubber: \$1450.00

Accumulator:
Make & Model: Burnsco-Bison
Capacity of Hydraulic Fluid: 250 gals
Number of Stations: 5 Number of Pressure Bottles: 8
Hydraulic Pressure Source: yes
Electric Motor: yes
Gas/Diesel Engine: N/A
Air/Hydraulic Pump: yes
Date of Last Inspection: Current

Choke Manifold:
Valves: Make & Model: 3 1/2 3,000lb. & 2 1/16 5,000lb
Pressure Rating & Size: 3000 - 5000
Date of Last Inspection: current
Chokes: Make & Model: 2" Type: Adj.Choke
Pressure Rating & Size: 5000
Date of Last Inspection: current

Light Plant:
Voltage, Amperage, Watts: 480 volts 615amp 410 KW 512KVA
Engine Make & Model: Cats 3406

Drilling Recorder:
Make & Model: Pason EDR (electronic drilling recorder)
Chart Type: 12 Hour X 24 Hour

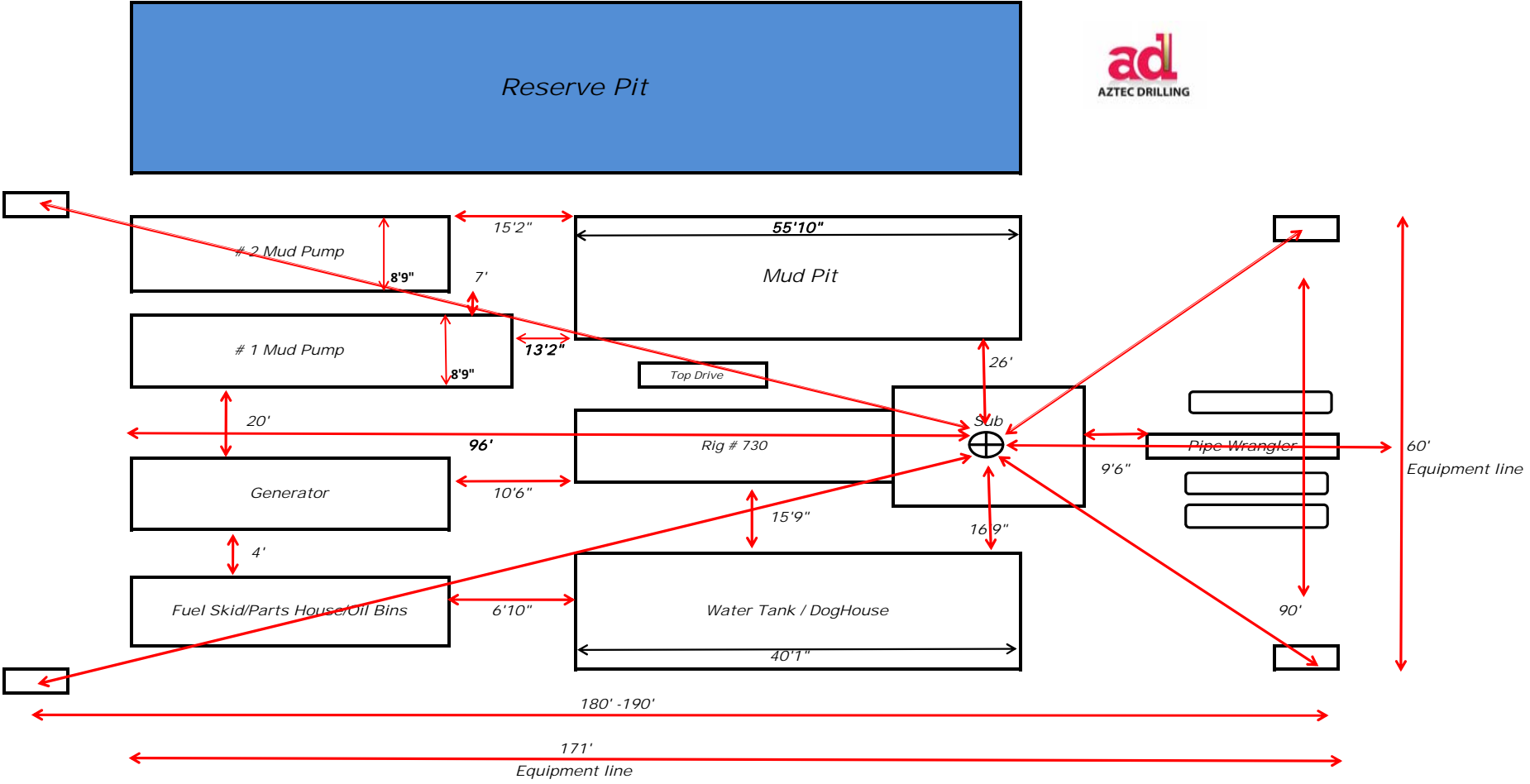

Rig 730 Foot Print